



August 22, 2024

Luke Sutton P.E.  
Assistant Union County Engineer  
233 West 6th Street,  
Marysville, Ohio 43040

Re: Del Web Jerome Horizontal Alignment (centerline radius) Request

Dear Mr. Sutton:

We are requesting variance of the Union County Subdivision Regulations Section 101 Street Design Part H Horizontal Alignment requirements for the Del Web Jerome project located north of Mitchell-Dewitt Road and west of Industrial Parkway. We are requesting a variance to the requirements to match the Township approved Planned Unit Development (PUD) plan. The applicable subdivision regulations are as follows:

**Subdivision Regulations Union County, Ohio Effective November 3, 1997**

**Section 101.H – Horizontal Alignment:**

1. Reduce the centerline radius on the entry road or Street A as shown on the preliminary plat from 300 ft to 200 feet for a collector road.
  - a. The Del Web community guidelines require an unloaded entry road with significant landscaping and open space on either side of the road to provide a unique entry to the development. The design of the entry road generally follows the riparian setback along the west edge of the road which required the 200-foot centerline radius. We would also like to keep the speed limit at 25-mph on this road the same as the local streets. The 200-foot centerline radius meets the 25-mph local street design requirements.
2. Reduce the centerline radius on street H as shown on the preliminary plat from 150 feet to 50 feet.
  - a. The reduction in the centerline on street H is to provide a central landscaping island between the front of the houses along this road. The turning radius of the proposed street H meets the fire truck turning requirements, see attached exhibit, and typical cul-de-sac requirements.

If you have any questions or require any additional information, please contact me at 614-348-0765.

Sincerely,

**Kevin Kershner, P.E.**  
Kimley-Horn and Associates, Inc.  
Phone: 614-472-8963  
Email: Kevin.Kershner@kimley-horn.com

CC: Brad Bodenmiller – Director LUC Regional Planning  
Eric Snowden, Jerome Township Zoning Inspector

Drawing name: C:\Users\GAL~1\OneDrive\AppData\Local\Temp\AcPublish\_9208\2024-0822\_Fire Truck Exhibit.dwg Layout1 (5) Aug 22, 2024, 10:17am by: Coll Hoopner

This document, together with the concepts and designs presented herein, is intended only for the specific purpose and client for which it was prepared. Reuse of and improper reliance on this document without written authorization and adaptation by Kimley-Horn and Associates, Inc. shall be without liability to Kimley-Horn and Associates, Inc.

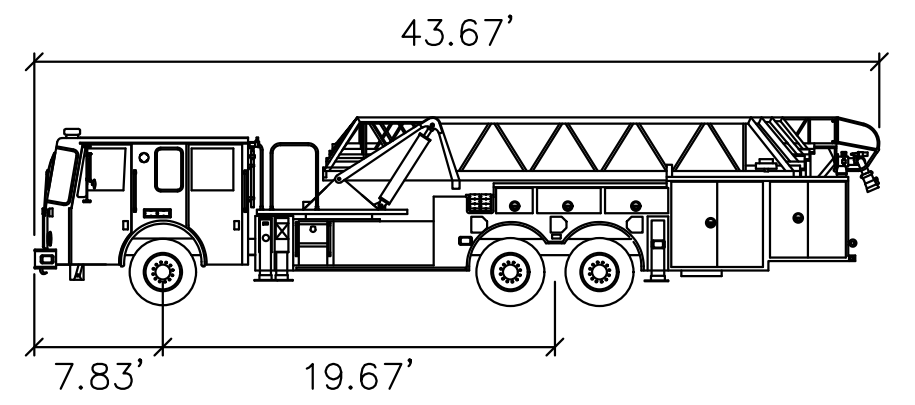
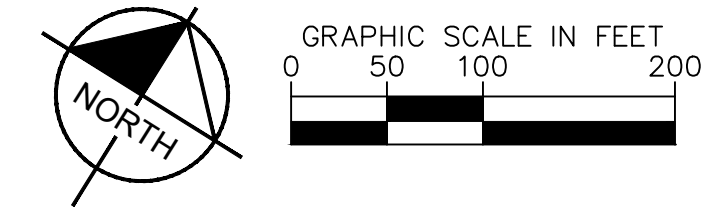

Sutphen 2011 Aerial  
Tower (236" Wheel Base)

- Width : 8.33'
- Track : 8.17'
- Lock to Lock Time : 6.0s
- Cramp Angle : 42.0°
- Wall to Wall : 40.25'  
(24" Bumper)

MITCHELL-DEWITT RD

SCALE: AS NOTED

DESIGNED BY:

DRAWN BY: AGH

CHECKED BY: KDK

**Kimley»Horn**

© 2024 KIMLEY-HORN AND ASSOCIATES, INC.  
7960 WOODBINE BLVD., SUITE 200  
COLUMBUS, OH 43235  
PHONE: 614-454-6899  
WWW.KIMLEY-HORN.COM

**FIRE TRUCK  
TURNING EXHIBIT**

**DEL WEBB - JEROME**  
JEROME TOWNSHIP  
UNION COUNTY, OHIO

ORIGINAL ISSUE:  
8/22/2024

KHA PROJECT NO.  
190013029

SHEET NUMBER

**EX-4**

No.	REVISIONS	DATE	BY	APR DATE	APR BY